

0/155PV
SIRIUS

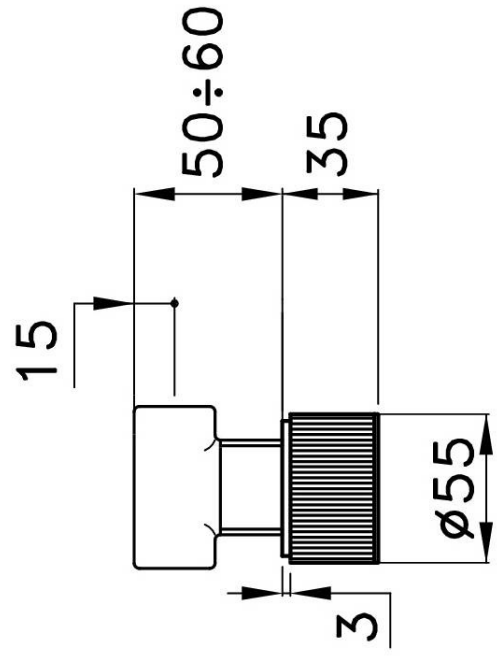
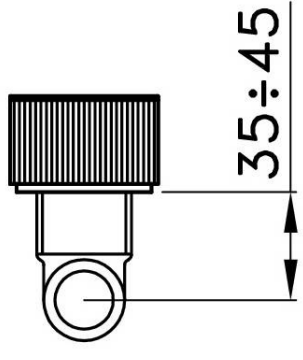
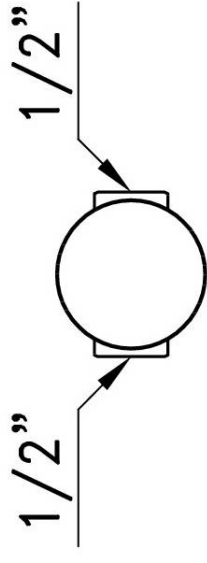

Rimuovere i cappucci di protezione e montare le prolunghе.
Tagliare le stesse nella misura indicata nello schema.

Retirez les capuchons de protection et installer les extensions.
Coupez-les dans la mesure indiquée dans le diagramme.

Remove the protective caps and fit the extensions.
Cut them to the extent indicated in the diagram.

Retire las tapas protectoras y ajuste las extensiones.
Córtelos en la medida indicada en el diagrama.

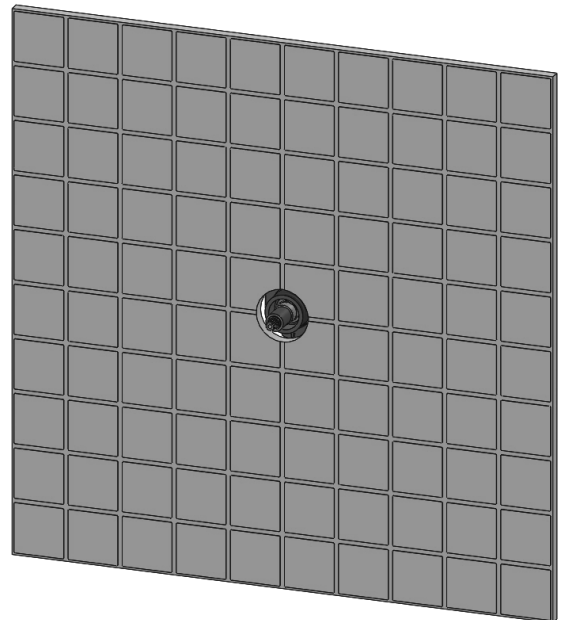
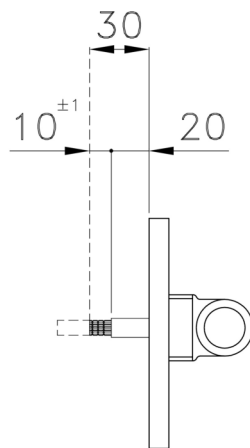
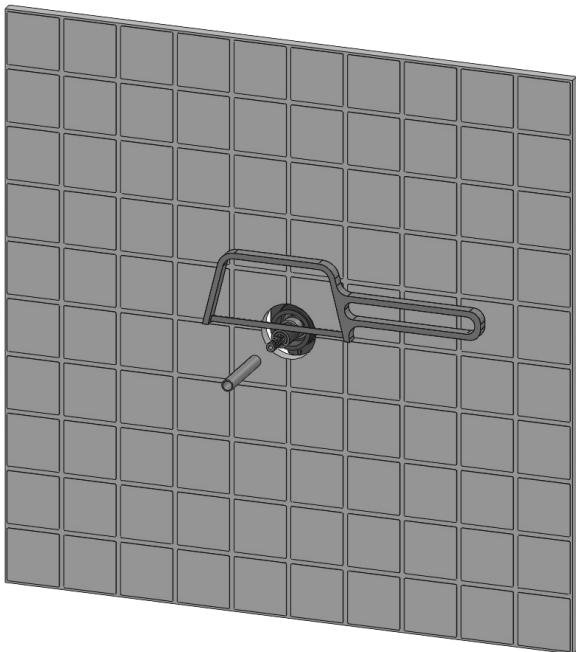
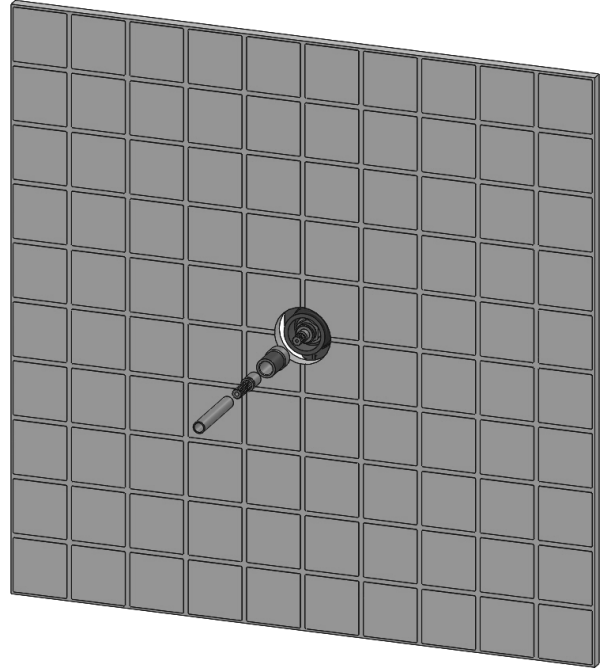
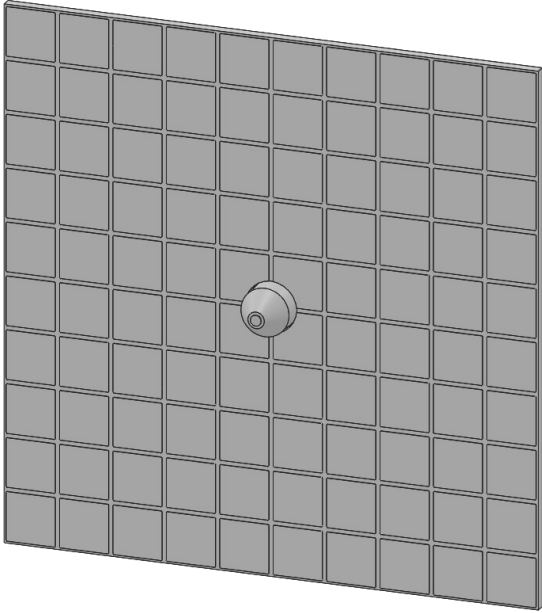

Installare le piastre di copertura.
Montare le maniglie (accorciare la vite se necessario).

Installez les plaques de recouvrement.
Monter les poignées (raccourcir la vis si nécessaire).

Install the cover plates.
Fit the handles (shorten the screw if necessary).

Instale las placas de cubierta.
Coloque las asas (acorte el tornillo si es necesario).

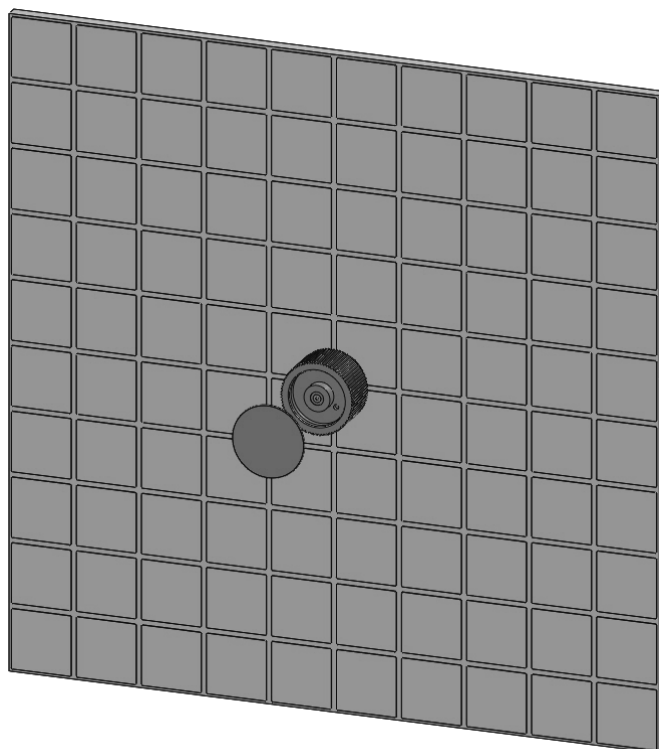
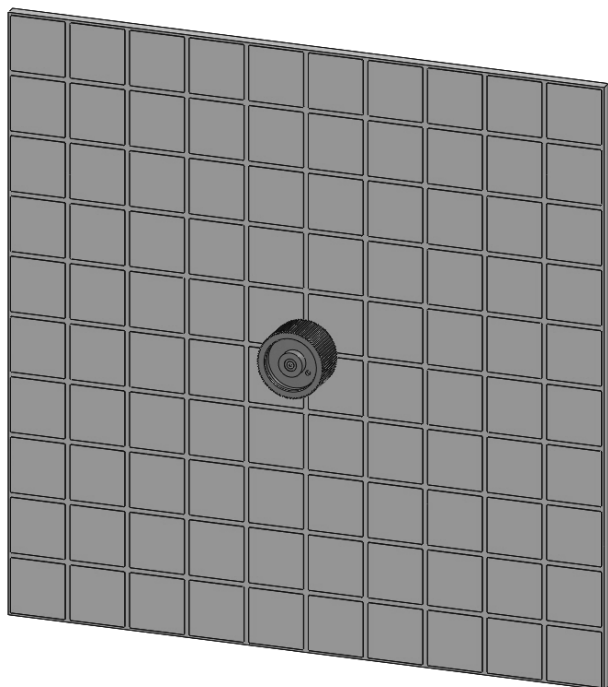
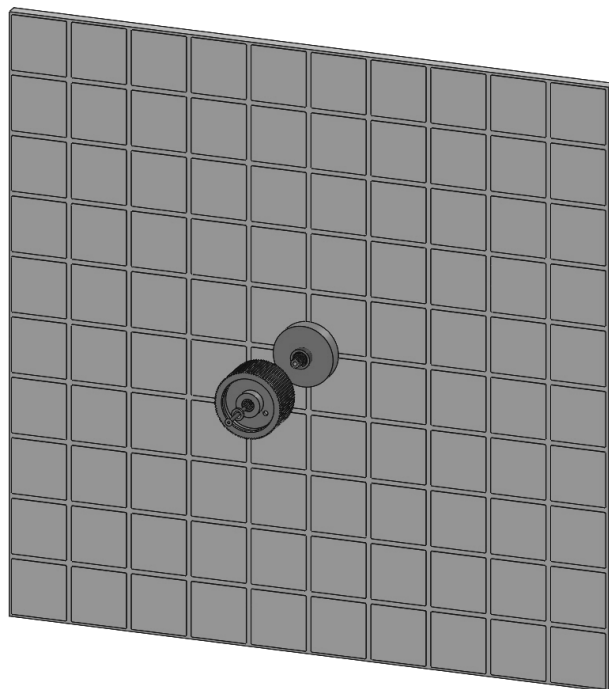
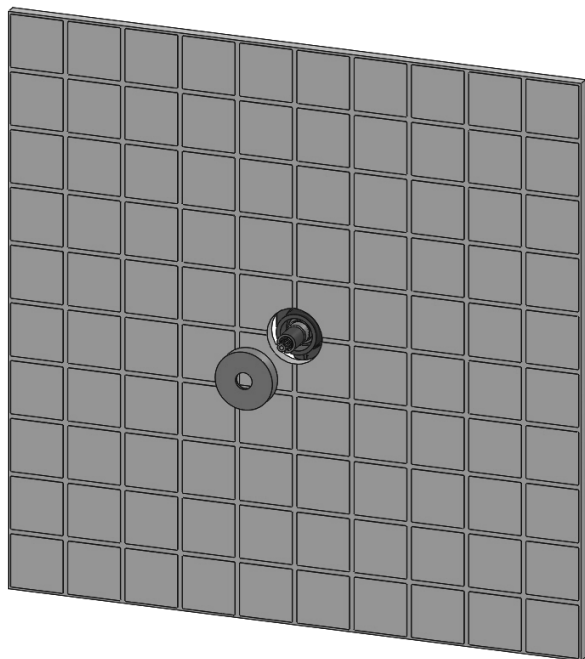

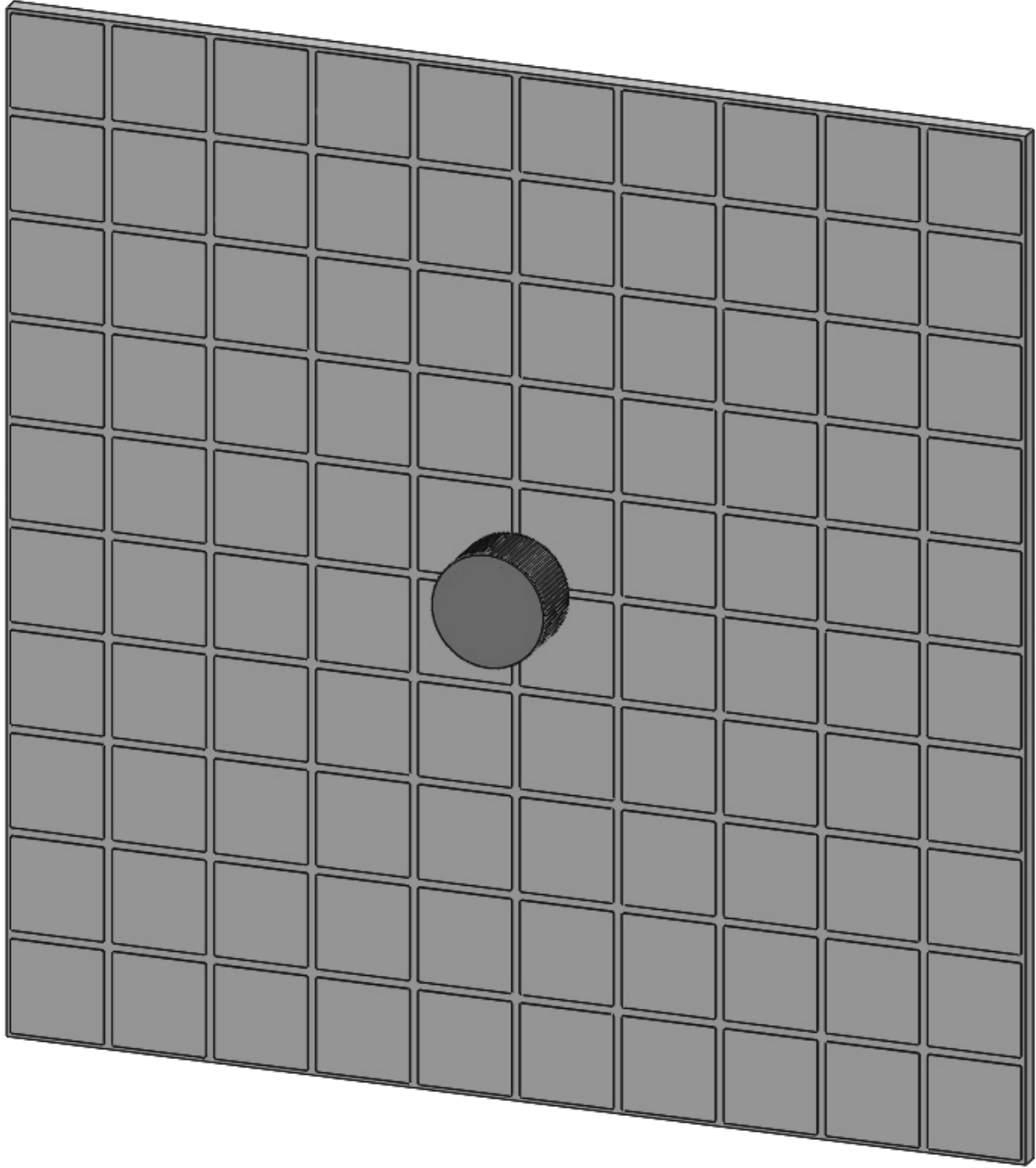

GARANZIA

Tutti i nostri prodotti sono realizzati a "regola d'arte" e sottoposti a scrupolosissimi controlli durante ogni fase del processo produttivo e la proverbiale robustezza e affidabilità che li caratterizza ci consentono di accordare una garanzia, a valere dalla data d'installazione:

- illimitata: su tutti i corpi da incasso in bronzo
- di 5 anni: su tutta la nostra produzione in finitura cromo e sugli elementi non superficiali delle rubinetterie in altra finitura
- di 2 anni: sulle parti in vista delle serie in finitura Nichel, Ottone Protetto, Argento e Oro

In applicazione della normativa europea, recepita da apposita legge italiana, la garanzia copre ogni difetto di fabbricazione (difetti di fusione, di lavorazione meccanica e di finitura) previo controllo del pezzo difettoso da parte del nostro Ufficio Tecnico.

La garanzia non copre il materiale che presenti le seguenti situazioni:

- normale usura o danni causati da eccesso di calcare nell'acqua (guarnizioni, rompigetti, fondelli di soffioni, ecc.) o dal gelo
- deterioramento delle superfici dovuto a utilizzazione di materiali per la pulizia non idonei o a pulizia delle superfici effettuata in modo non corretto senza tener conto delle nostre istruzioni
- deterioramento causato da installazione non corretta
- anomala utilizzazione della rubinetteria
- riparazioni e/o manutenzioni mal effettuate e/o utilizzazione di ricambi inadatti o non originali Stella

La garanzia si limita alla riparazione o alla sostituzione dei pezzi difettosi, da effettuarsi nel nostro stabilimento o nei centri assistenza da noi autorizzati, e non copre i costi di smontaggio, rimontaggio ne eventuali danni ai rivestimenti o ai sanitari.

RECLAMI:

Eventuali reclami di qualsiasi genere devono pervenire per lettera raccomandata entro 8 giorni dall'arrivo a destinazione della merce.

CONTESTAZIONI:

Per ogni contestazione è riconosciuta la sola competenza del Foro di Novara.

WARRANTY

All other products are superbly crafted and are subject to the most stringent tests in each stage of the production process: their celebrated sturdiness and reliability means that we are able to cover them with the following warranties as from the date of installation:

- unlimited on all recessed units in bronze
- 5-year: on all chrome-plated products and all non-surface elements of taps with other finishes
- 2-year: on exposed parts in the nickel-finish, protected brass, silver and gold-finish collections.

In accordance with European regulations, implemented by a special Italian law, the warranty cover any manufacturing defects (casting defects, mechanical processing and finishing), subject to inspection of the defective part by our Engineering Departement.

The warranty does not cover materials in the following conditions:

- normal wear or damage caused by excessive limestone in the water (washers, aerators, showerhead plates, etc.) or freezing.
- deterioration of surfaces due to the use of unsuitable cleaning products or cleaning of the surfaces carried out incorrectly and not in accordance with our instructions.
- deterioration caused by incorrect installation
- anomalous use of the taps
- repairs and/or maintenance carried out incorrectly and/or with the use of unsuitable or non-original spare parts

The warranty covers only the repair or replacement of the defective part, to be carried out in our factory or in technical assistance centres authorised by Stella. It does not cover the costs of disassembly, reinstallation or any damage caused to surface materials or to sanitary fittings.

COMPLAINTS:

Any complaint of any kind must be sent by registered letter within eight days of the arrival of the goods at destination. Should no complaint be made before such time, the products will be considered to have been accepted by the Purchaser.

REGULATIONS:

Most of our products are made in compliance with those European Union (EU), regulations that may be applicable to them. Except in the case of an explicit declaration by Rubinetterie Stella S.p.A., no guarantee is issued concerning compliance of the products with national rules and regulations – expressly including safety and accident-prevention standards in force in the country of the Purchaser – should the latter the resident outside the EU or, more in general, in any nation that is not a member of the EU.

DISPUTES:

The Court of Novara shall be the sole court of jurisdiction for the resolution of any disputes.

GARANTIE

La garantie sur notre robinetterie couvre tout défaut de fabrication, à condition qu'elle ait été installée par des professionnels qualifiés suivant les règles de l'art, conformément à la législation en vigueur et selon nos instructions de montage.

La durée de la garantie est de 5 ans à compter de la date d'installation, à l'exception des traitements spéciaux et des revêtements autres que le chrome (2 an). La garantie ne couvre pas l'usure normale des pièces en mouvement, les conditions d'utilisation anormales, les dommages consécutifs à la nature des eaux, à l'incendie ou au gel. La garantie se limite à la réparation ou au remplacement en nos atelier du matériel reconnu défectueux. Elle ne prend pas en compte les frais de pose et de dépose ni d'éventuels dommages et intérêts, notamment pour privation de jouissance.

NORMES:

Nos robinetteries sont conformes à plusieurs Normes Européennes EN actuellement en vigueur. Les classements NF et EPEBAT son également attribués à la plupart de nos mélangeurs dont la liste peut être communiquée sur demande.

GARANTIA

Todos nuestros productos están hechos en manera profesional y se someten a controles escrupulosos en cada etapa del proceso de producción; la robustez legendaria y la fiabilidad que los caracteriza nos permite ofrecer una garantía, válida desde la fecha de instalación:

- Garantía de por vida en todos los cuerpos construidos en bronce
- 5 años de garantía en todos nuestros productos en acabado cromo y los elementos en la superficie de grifería en otro acabado
- 2 años de garantía sobre las partes visibles de las series con acabado en níquel, cobre protegido, plata y oro.

En conformidad con la normativa europea, ejecutado por una ley italiana, la garantía cubre cualquier defecto de fabricación (defectos de fusión, de mecanizado y acabado) después que nuestra Oficina Técnica controle la parte defectuosa.

La garantía no cubre el material que tiene las siguientes situaciones:

- El desgaste normal o daños causados por el exceso de calcio en el agua (juntas, aireador, fondos de alcachofas de ducha, etc.) o debido al hielo
- deterioro de las superficies debido al uso de materiales inadecuados de limpieza o incorrecta limpieza de las superficies sin tener en cuenta nuestras instrucciones
- Los daños causados por una instalación incorrecta
- utilización inusual de los grifos
- Reparación y / o mantenimiento mal hechos y / o el uso de piezas de repuesto inadecuadas o no originales Stella

La garantía se limita a la reparación o al reemplazo de piezas defectuosas, que se realizará en nuestra fábrica o centros de servicio autorizados por nosotros, y no cubre los gastos de extracción, sustitución o cualquier daño a las capas o a los sanitarios.

QUEJAS

Quejas de cualquier tipo deben ser enviadas por correo certificado dentro de los 8 días de llegada a destino de los productos.

CONTROVERSIAS

Para cada controversia se reconoce la competencia exclusiva del Tribunal de Novara.

Rubinetterie Stella S.p.A.

Via Monte Bianco, snc
28040 Dormelletto (NO)

TEL: (+39) 0321 473351

FAX: (+39) 0321 474231

e-mail: info@rubinetteriestella.it

www.rubinetteriestella.it